



IOP19C4C
Integral Camera and Lens for
SB1900 Series Preset Domes

Installation/Operation Manual

C720M (1/96)

TABLE OF CONTENTS

Section	Page
1.0 WARNINGS	1
2.0 SCOPE	1
3.0 DESCRIPTION	1
4.0 INSTALLATION	2
5.0 ELECTRICAL WIRING	4
6.0 ADJUSTMENTS	5
6.1 BACK FOCUS	5
6.2 SHUTTER SPEED	5
6.3 AUTO GAIN CONTROL	5
6.4 WHITE BALANCE (ATW/AWB SWITCH)	6
6.5 V-PHASE (VERTICAL PHASE)	6
6.6 AUTO IRIS	6
7.0 EXPLODED ASSEMBLY DRAWING	9
7.1 PARTS LIST FOR FIGURE 8, TVH6 SERIES	9
8.0 MODELS	10
9.0 SPECIFICATIONS	10
10.0 WARRANTY AND RETURN INFORMATION	11

®PELCO and the PELCO logo are registered trademarks of PELCO.
©Copyright 1996, PELCO. All rights reserved.

LIST OF ILLUSTRATIONS

Figure		Page
1	TVH6 Series Camera Dimensions	1
2	IOP Package Installation	2
3	Wiring Diagram for SB1900 Preset Dome and IOP Package With Presets	3
4	Schematic Diagram for Color Camera/Lens	4
5	Back Focus Adjustment	6
6	Camera Adjustments	7
7	Camera Adjustment Locations	8
8	TVH6 Series Camera/Lens Combination Exploded Assembly Drawing	9

REVISION HISTORY

Manual #	Date	Comments
C720M	1/96	Original version.

(This page intentionally left blank.)

**INSTALLATION/OPERATION MANUAL
MODEL IOP19C4C
INTEGRAL CAMERA & LENS PACKAGE
FOR SB1900 SERIES PRESET DOMES**

1.0 WARNINGS

Prior to installation and use of this product, the following WARNINGS should be observed.

1. Installation and servicing should only be done by Qualified Service Personnel and conform to all Local codes.
2. Unless the unit is specifically marked as a NEMA Type 3, 3R, 3S, 4, 4X, 6, or 6P enclosure, it is designed for indoor use only and it must not be installed where exposed to rain and moisture.
3. Only use replacement parts recommended by Pelco.
4. After replacement/repair of this unit's electrical components, conduct a resistance measurement between line and exposed parts to verify the exposed parts have not been connected to line circuitry.
5. The installation method and materials should be capable of supporting four (4) times the weight of the enclosure, pan/tilt, camera and lens combination.

2.0 SCOPE

The information contained in this manual covers the IOP019C4C integral camera and lens package for the SB1900 Series preset domes.

3.0 DESCRIPTION

The IOP19C4C is a high-resolution, color camera and lens package with presets specifically designed for use in the SB1900 series preset domes. This integral camera and lens package was designed to provide a competitively priced camera without compromising the quality of the video picture.

Design considerations were engineered into this integral camera and lens combination to ensure ease of servicing.

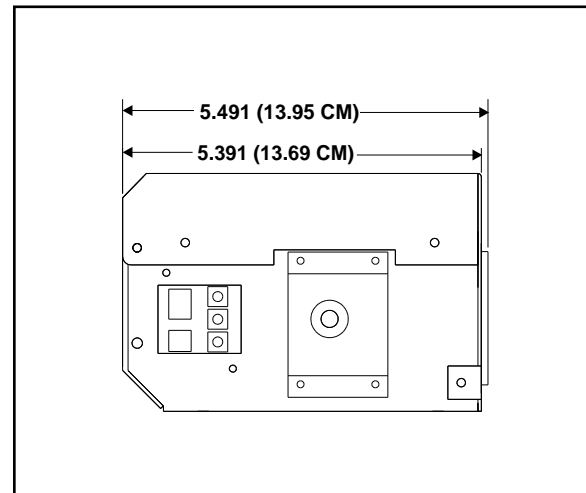

Figure 1. TVH6 Series Camera Dimensions

Please thoroughly familiarize yourself with the information in this manual prior to installation and operation.

4.0 INSTALLATION

CAUTION: Make certain not to drop or jar the camera and lens combination or damage will result to the unit.

To install the camera and lens package in your dome, please follow the steps outlined below. Refer to Figure 2, if necessary.

1. **Disconnect main power to back box.**
2. Remove dome drive from back box.
3. Insert the two (2) 1/4-20 studs on the IOP package through the slots in tilt table with the IOP facing the front of the tilt table. From the bottom place a split lock washer and a 1/4-20 nut on each stud. Tighten down nuts just snug.
4. Make all electrical wiring and other connections as shown in Figure 3.
5. Insert the dome drive into the back box. Adjust the IOP package on the tilt table so that it is as close to the dome as possible (without hitting when tilted up or down). Then securely tighten nuts on IOP package.

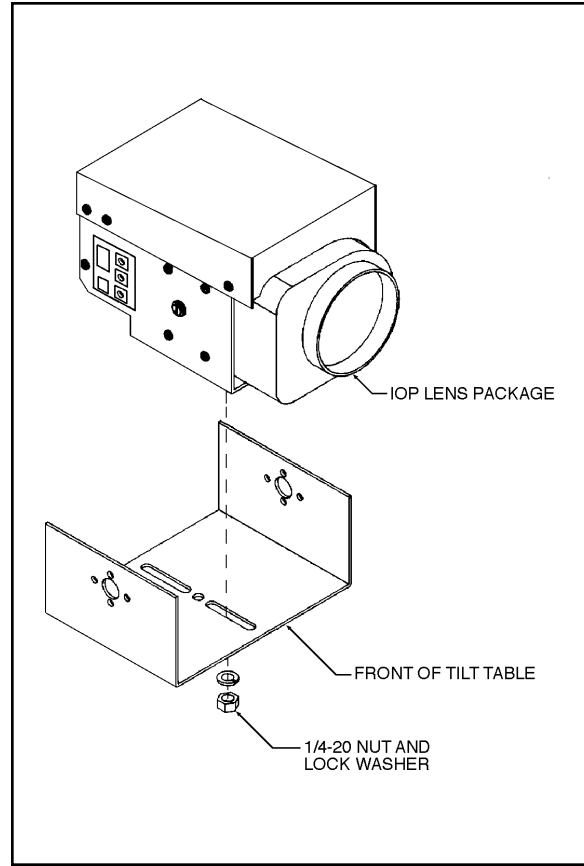

Figure 2. IOP Package Installation

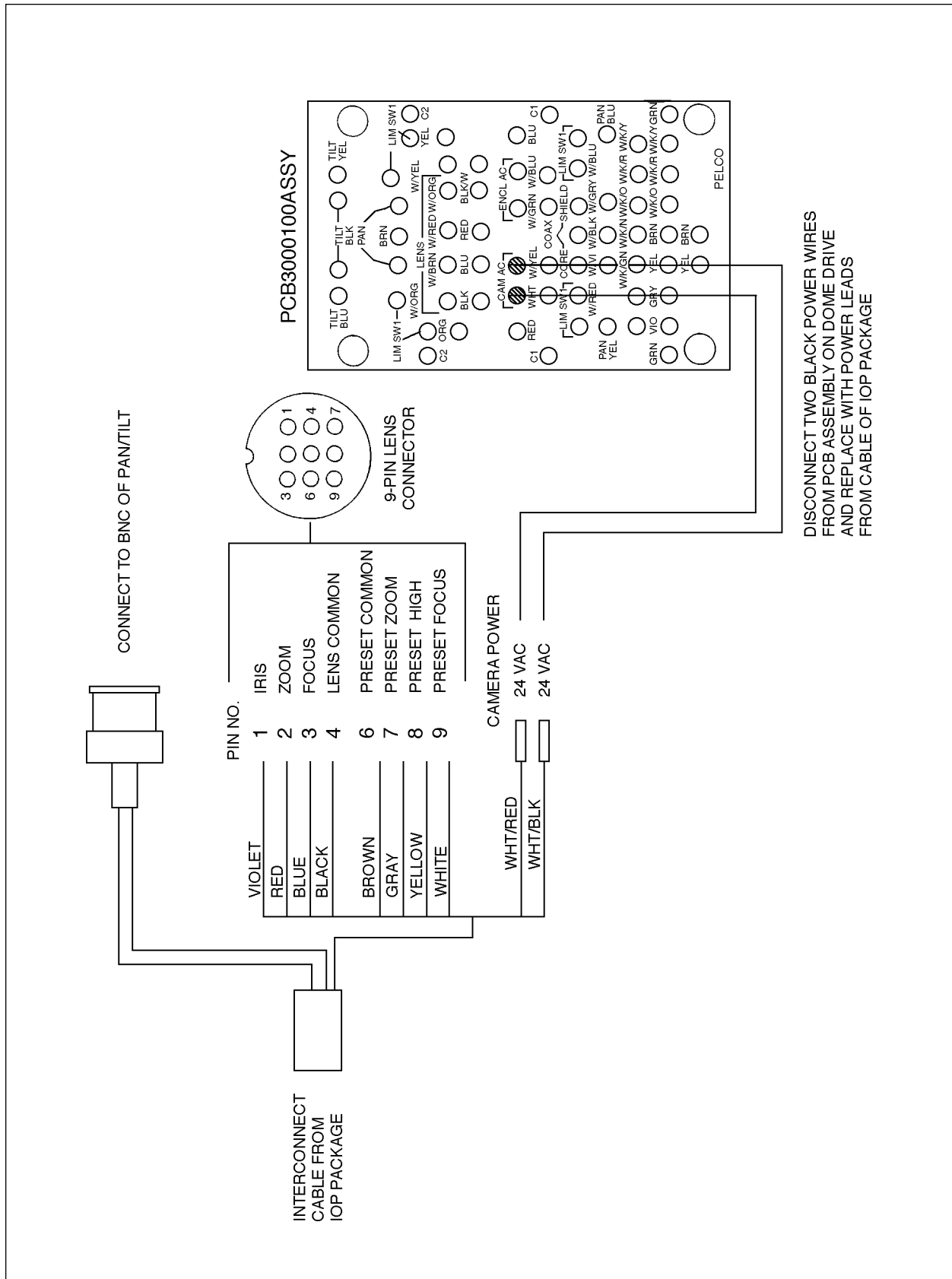

Figure 3. Wiring Diagram for SB1900 Preset Dome and IOP Package With Presets

5.0 ELECTRICAL WIRING

See Figure 4 below for wiring diagram of the IOP19C4C camera and lens module.

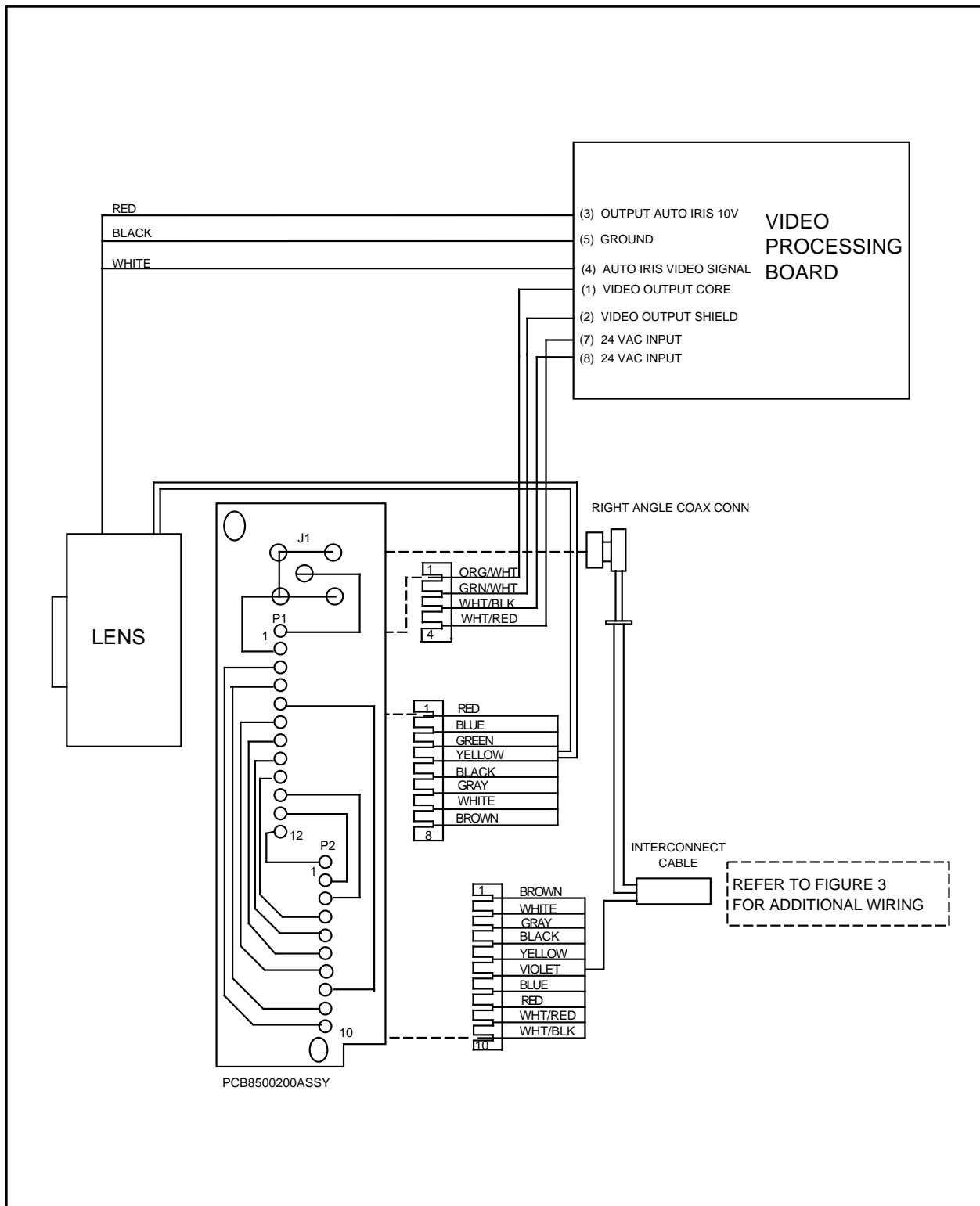

Figure 4. Schematic Diagram for Color Camera/Lens

6.0 ADJUSTMENTS

Your optics package comes factory adjusted for a broad range of lighting conditions. For this reason, you may find it necessary to adjust your optics package to tailor the picture to your specific viewing environment. The following adjustments can be made to the Pelco optics package.

- Back focus
- Shutter speed
- AGC
- White balance
- V-Phase (Vertical Phase)
- Auto iris level

The factory adjustments for the above controls are set as follows:

➤ **Back Focus**

Adjusted with focus far/zoom wide looking at an object 55 feet (16.76 m) from the lens. The results are a clear, in-focus picture through the entire zoom range (reference Figure 5 for back focus adjustment location).

➤ **Shutter Speed**

Factory set to the slowest speed available: 1/60 second on NTSC units; 1/50 second on PAL units.

➤ **Auto Gain Control**

AGC ON/OFF set to ON.

➤ **White Balance**

White balance has two positions; one is ATW (Automatic Tracing White), which is a feature that continuously adjusts the camera for optimum color reproduction. AWB (Automatic White Balance) is a feature that retains current settings in memory even when the power is off.

➤ **V-Phase (Vertical Phase)**

See section 6.5.

➤ **Auto Iris**

Level is adjusted using a video meter to provide a video signal output of between 130 and 142 IRE (Institute of Radio Engineers; 1V p-p = 100 IRE's) when lighting from skylights, low pressure sodium lights and fluorescent lights are present. ALC is adjusted to the midpoint between Peak and Average.

The location for the controls of the above features, except for back focusing, are shown in Figures 6 and 7. Back focusing is addressed in Figure 5. The following sections will define the above features and specify how to adjust them to gain the best system performance in your environment.

6.1 BACK FOCUS

Back focusing involves controlling the distance between the focal point of the lens and the image head. If the lens is focused on the imaging head properly, a clear picture is maintained through the entire zoom range. The optics package has been back focused at the factory. In some cases, additional back focusing may be required. Should this be the case, back focus is adjusted by moving the lens positions to zoom wide and focus far. Once this is done, the camera is positioned on an object with clean lines such as a window seal, shelf, etc., at a minimum distance of 55 feet (16.76 m). The back focus adjustment screw location is shown in Figure 5. It can be adjusted with a small standard straight slotted screwdriver. The screw itself is recessed a bit from the camera housing as indicated in the figure. The mechanical movement of the screw as the screwdriver is turned is about three “clicks” or indents in either direction. As you move the back focus set screw back and forth, the distance between the lens and image head moves in and out. You will be able to see the clean line come in and out of focus. Continue to adjust the screw back and forth until the optimum focus is obtained.

6.2 SHUTTER SPEED

This optics package is provided with adjustable shutter speeds. This feature allows minimal streaking when a very fast moving object passes in front of the non-moving optics package. The shutter speed is factory set to 1/60 second. Shutter speed selection does not affect the auto iris video feedback loop. It only changes the imaging head sampling rate. You can select one of eight shutter speeds (reference the details in Figures 6 and 7).

6.3 AUTO GAIN CONTROL

Reference Figure 6. The AGC control setting should be set and left in the “ON” position.

6.4 WHITE BALANCE (ATW/AWB SWITCH)

White balance is a feature available on the color optics packages. In the ATW (Automatic Tracing White Balance) position, the white balance is continuously adjusted to take into account variations in the incident light conditions. In the AWB (Automatic White Balance) position, when the "LOCK" button is pressed, the white balance is automatically adjusted, and the setting is stored in memory. When the switch is set to this position the white balance always takes the previously stored value. White balance is factory set to the AWB position and it is recommended that the optics package be used in the mode just described.

6.5 V-PHASE (VERTICAL PHASE)

V-Phase (Vertical Phase) is valuable when multiple optic packages are switched by a sequential or matrix switcher. The vertical phase +/- buttons are used to compensate for vertical phase discrepancies which will occur in a multiple camera environment. In this type of environment, each camera's output is synchronized by the frequency of the power supply and phase. The "+" and "-" buttons referenced in Figure 6 can be used to obtain a synchronized picture. The user can adjust them by placing one person at the optics package location and another at the control room looking at a monitor viewing switching video signals from the optics packages. The V-phase adjustment is ± 90 degrees. Use the tip of a ball-point pen or similar instrument to press these recessed buttons. The phase change is linear. Pressing a button will activate a phase change in the direction indicated. The phase change will begin after about one-half second, but the switch must be held down for a total of five or six seconds for the phase change to occur. An equal amount of time is required to go in the opposite direction. Each optics package should be adjusted so that as the switchers switch from one optics package to the next, the monitor does not "roll" or show partial frames of the video picture.

6.6 AUTO IRIS

As an option, this optics package may have an "active" auto iris lens. An active auto iris lens is fed back information from the camera imaging head to the auto iris circuitry of the lens. The lens processes this information and tries to maintain a constant light level to the image head at all times. The auto iris lens has two controls which may be field adjusted. These controls are "LEVEL" and "ALC". From the factory, the optics package is set to handle a general wide range of lighting conditions. To set the optics package in the field

for your specific lighting condition, you must first determine if the picture on the viewing monitor is too bright or too dim. Before adjusting the Iris controls, the monitor controls must be set at their "detente" (or notched) factory recommended positions (not having all controls for contrast, picture, color, tint, etc. adjusted for maximum intensity). If a very dim picture is present, this would indicate that the iris could be opened a little more to allow additional light to be imposed on the image head. To brighten the picture, the "LEVEL" control should be rotated clockwise to allow more light to be shown on the image head. If the picture is too bright, rotating the "LEVEL" control counterclockwise will allow less light to be shown on the image head and the picture on the monitor will become dimmer. If the installation site has varying light conditions due to storefront windows, several adjustments may be necessary to ensure adequate overall performance. As an alternate (more objective) method of adjusting the iris, an oscilloscope or video meter may be connected to the output of the optics package and the "LEVEL" control adjusted for a 1 volt peak-to-peak video signal out. Lastly, the "ALC" control can be adjusted to either Peak or Average sampling levels. Peak levels are obtained by rotating the "ALC" control clockwise. Counterclockwise rotation of the "ALC" control results in more average levels. Peak levels may be necessary if you want to view dark objects in a bright setting. This condition is commonly known as backlight compensation. Peak settings tend to open the iris a little more and average levels tend to close the iris a little given the light sampling rate of the lens.

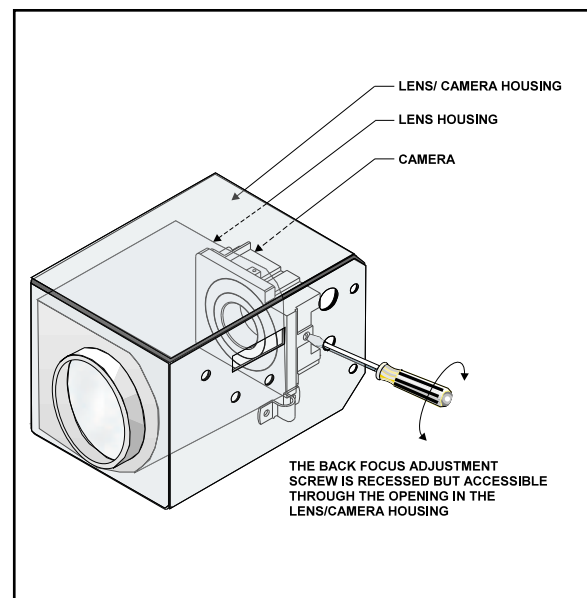

Figure 5. Back Focus Adjustment

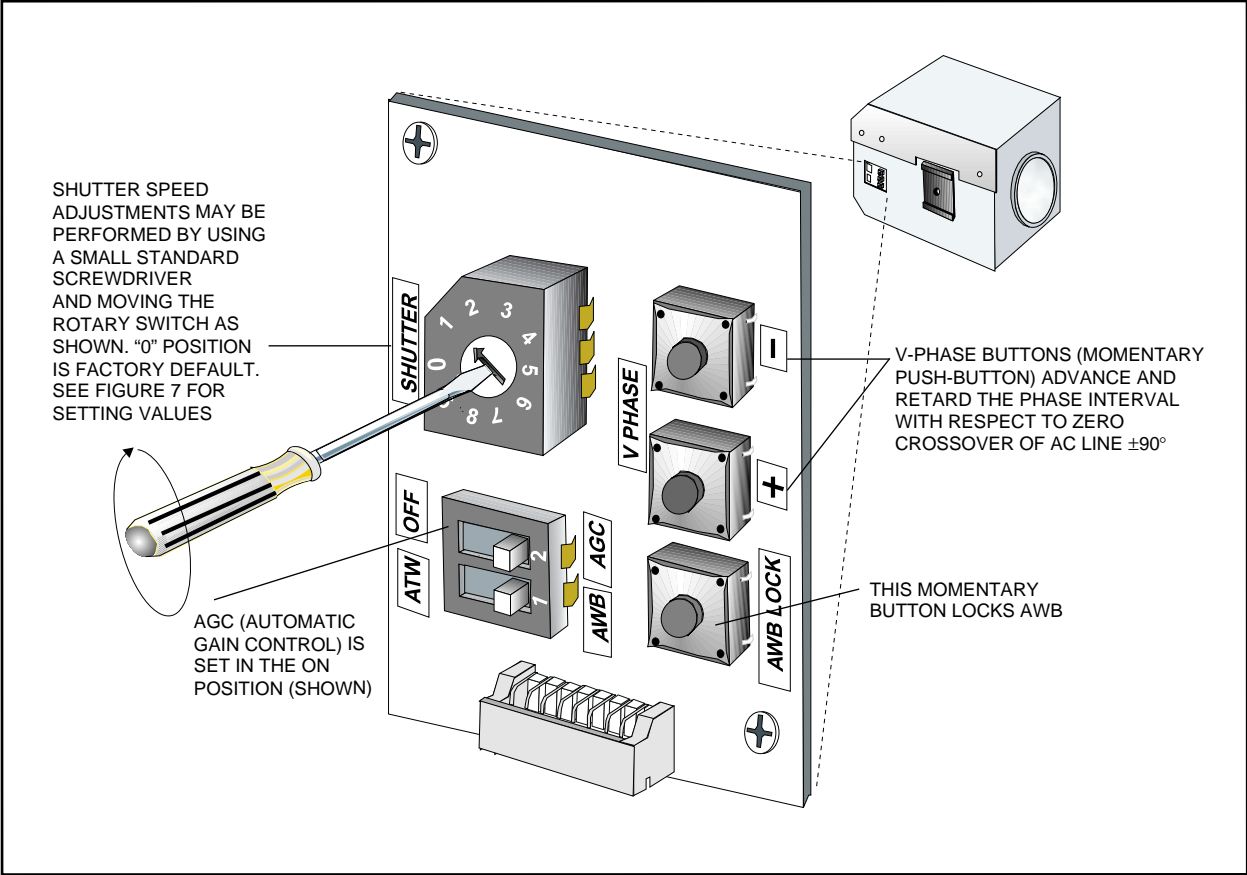
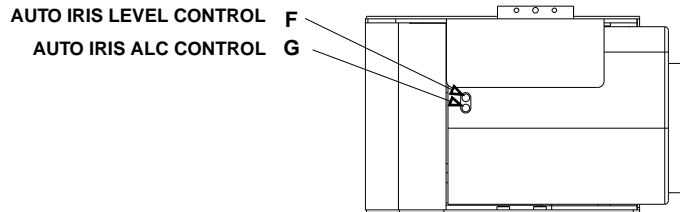
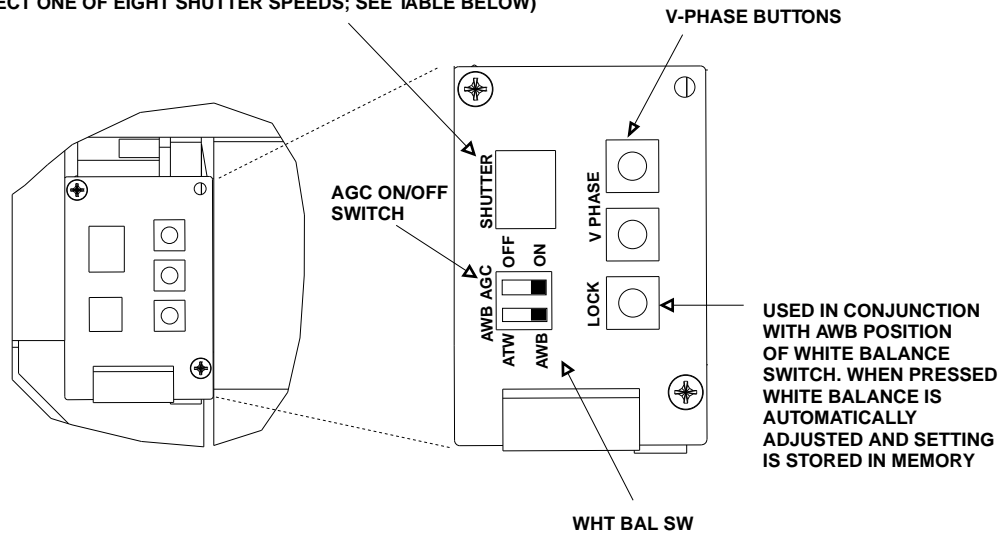

Figure 6. Camera Adjustments

SHUTTER SPEED CONTROL
 (YOU CAN SELECT ONE OF EIGHT SHUTTER SPEEDS; SEE TABLE BELOW)



SHUTTER POSITION	SHUTTER SPEED (IN SECONDS)	
	NTSC	PAL
0	1/60	1/50
1	1/100	1/100
2	1/250	1/250
3	1/500	1/500
4	1/1000	1/1000
5	1/2000	1/2000
6	1/4000	1/4000
7	1/10000	1/10000
8	NOT USED	NOT USED
9	NOT USED	NOT USED

Figure 7. Camera Adjustment Locations

7.0 EXPLODED ASSEMBLY DRAWING

If necessary, refer to Figure 8 for an exploded assembly drawing and parts list.

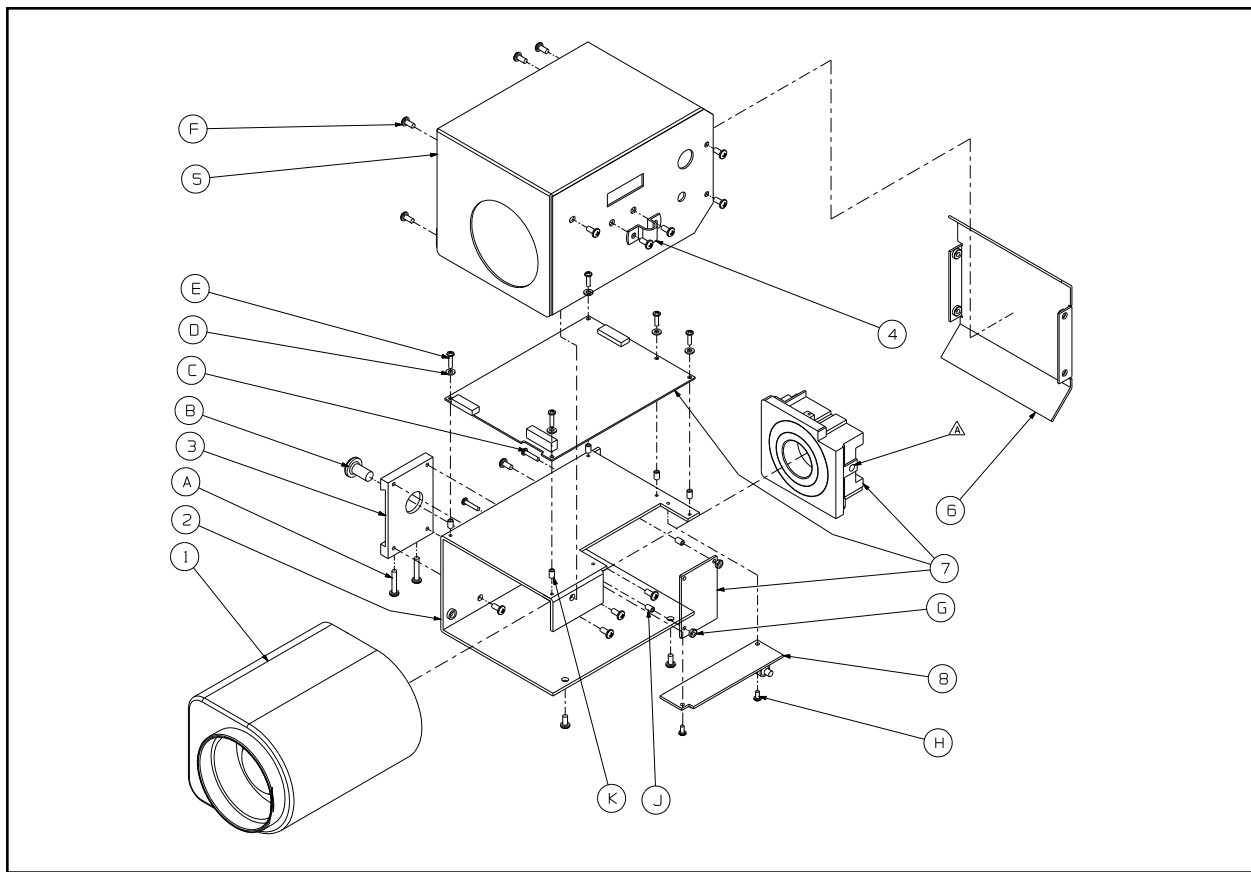

Figure 8. TVH6 Series Camera/Lens Combination Exploded Assembly Drawing

7.1 PARTS LIST FOR FIGURE 8, TVH6 SERIES

<u>Item</u>	<u>Qty</u>	<u>Description</u>	<u>Part #</u>
1	1	Lens, 1/2" motorized zoom, 8.5-51, f1.2 w/pp	H6Z851MP
2	1	Frame, 6X lens package for IOP19	Jiop084307COMP
3	—	NOT USED FOR THIS MODEL	—
4	1	Clamp, wire fatigue	80010016
5	1	Top cover	Jiop084106COMP
6	1	Back cover	Jiop084108COMP
7	1	Camera, Sony 1/2" color hi-res (PAL)	SC-CPL27P
8	1	PC board, IOP camera interconnect	PCB8500200ASSY
A	—	NOT USED FOR THIS MODEL	—
B	1	Screw, 1/4-20 x .375 flat, phil, SS	ZH1/4-20X.375SP
C	2	Screw, 2-56 x 1/2" phil, pan, SS M/S	ZH2-56X.500SPS
D	5	Washer, internal star, #2 SS	ZH2LWSIS
E	5	Screw, 2-56 x 3/8 phil, pan, SS	ZH2-56X.375SRS
F	16	Screw, 4-40 x 1/4" pan, phil, blk	ZH4-40X.250BPP
G	2	Nut, hex 2-56 SS	ZH2-56NUTSH
H	2	Screw, 2-56 x 3/16" phil, pan, SS	ZH2-56X.187SPS
J	2	Spacer, 3/16" dia. x .187", #2 clear	SPA9161
K	4	Spacer, 3/16" dia. x .125", #2 clear	SPA9160

8.0 MODELS

IOP19C4C High resolution color PAL (CCIR) series camera with integral 6X motorized zoom lens with presets.

9.0 SPECIFICATIONS

MECHANICAL

Mounting Bracket

Construction: 0.050" aluminum
Dimensions: See Figure 1

ELECTRICAL

Color PAL (CCIR) Camera Module

Input voltage: 24 VAC, 50 Hz
Power required: Less than 5 watts, plus auto iris of lens
Video output: 1 V p-p composite video into 75 ohms
Operating temperature: 14° to 131°F (-10° to 55°C)
Imaging device: 1/2" CCD
Illumination: 2.5 LUX @ F1.2
Scanning system: 625 lines, interlaced/50 Hz
Horizontal resolution: 470 TVL
Shutter speed: Adjustable, 1/50 to 1/10000 second, 8 steps
Automatic Gain Control: Present in auto mode only

10.0 WARRANTY AND RETURN INFORMATION

WARRANTY

Pelco will repair or replace, without charge, any merchandise proved defective in material or workmanship for a period of one year after the date of shipment.

Exceptions to this warranty are as noted below:

- Five years on FT/FR8000 Series fiber optic products.
- Three years on Genex® Series products (multiplexers, server, and keyboard).
- Three years on Camclosure® and fixed camera models, except the CC3701H-2, CC3701H-2X, CC3751H-2, CC3651H-2X, MC3651H-2, and MC3651H-2X camera models, which have a five-year warranty.
- Two years on standard motorized or fixed focal length lenses.
- Two years on Legacy®, CM6700/CM6800/CM9700 Series matrix, and DF5/DF8 Series fixed dome products.
- Two years on Spectra®, Esprit®, ExSite™, and PS20 scanners, including when used in continuous motion applications.
- Two years on Esprit® and WW5700 Series window wiper (excluding wiper blades).
- Eighteen months on DX Series digital video recorders, NVR300 Series network video recorders, and Endura™ Series distributed network-based video products.
- One year (except video heads) on video cassette recorders (VCRs). Video heads will be covered for a period of six months.
- Six months on all pan and tilts, scanners or preset lenses used in continuous motion applications (that is, preset scan, tour and auto scan modes).

Pelco will warrant all replacement parts and repairs for 90 days from the date of Pelco shipment. All goods requiring warranty repair shall be sent freight prepaid to Pelco, Clovis, California. Repairs made necessary by reason of misuse, alteration, normal wear, or accident are not covered under this warranty.

Pelco assumes no risk and shall be subject to no liability for damages or loss resulting from the specific use or application made of the Products. Pelco's liability for any claim, whether based on breach of contract, negligence, infringement of any rights of any party or product liability, relating to the Products shall not exceed the price paid by the Dealer to Pelco for such Products. In no event will Pelco be liable for any special, incidental or consequential damages (including loss of use, loss of profit and claims of third parties) however caused, whether by the negligence of Pelco or otherwise.

The above warranty provides the Dealer with specific legal rights. The Dealer may also have additional rights, which are subject to variation from state to state.

If a warranty repair is required, the Dealer must contact Pelco at (800) 289-9100 or (559) 292-1981 to obtain a Repair Authorization number (RA), and provide the following information:

1. Model and serial number
2. Date of shipment, P.O. number, Sales Order number, or Pelco invoice number
3. Details of the defect or problem

If there is a dispute regarding the warranty of a product which does not fall under the warranty conditions stated above, please include a written explanation with the product when returned.

Method of return shipment shall be the same or equal to the method by which the item was received by Pelco.

RETURNS

In order to expedite parts returned to the factory for repair or credit, please call the factory at (800) 289-9100 or (559) 292-1981 to obtain an authorization number (CA number if returned for credit, and RA number if returned for repair).

All merchandise returned for credit may be subject to a 20% restocking and refurbishing charge.

Goods returned for repair or credit should be clearly identified with the assigned CA or RA number and freight should be prepaid. Ship to the appropriate address below.

If you are located within the continental U.S., Alaska, Hawaii or Puerto Rico, send goods to:

Service Department
Pelco
3500 Pelco Way
Clovis, CA 93612-5699

If you are located outside the continental U.S., Alaska, Hawaii or Puerto Rico and are instructed to return goods to the USA, you may do one of the following:

If the goods are to be sent by a COURIER SERVICE, send the goods to:

Pelco
3500 Pelco Way
Clovis, CA 93612-5699 USA

If the goods are to be sent by a FREIGHT FORWARDER, send the goods to:

Pelco c/o Expeditors
473 Eccles Avenue
South San Francisco, CA 94080 USA
Phone: 650-737-1700
Fax: 650-737-0933

Pelco, the Pelco logo, Camclosure, Esprit, Genex, Legacy, and Spectra are registered trademarks of Pelco.
Endura and ExSite are trademarks of Pelco.

© Copyright 1999, Pelco. All rights reserved.



PELCO

300 West Pontiac Way
Clovis, CA 93612-5699 USA
(209) 292-1981 • (800) 289-9100
FAX (800) 289-9150 or (209) 292-3827 DataFAX (800) 289-9108 or (209) 292-0435

International customers call 1-209-292-1981 or FAX 1-209-348-1120

(Product specifications subject to change without notice.)

C720M